

RoHS

Reach

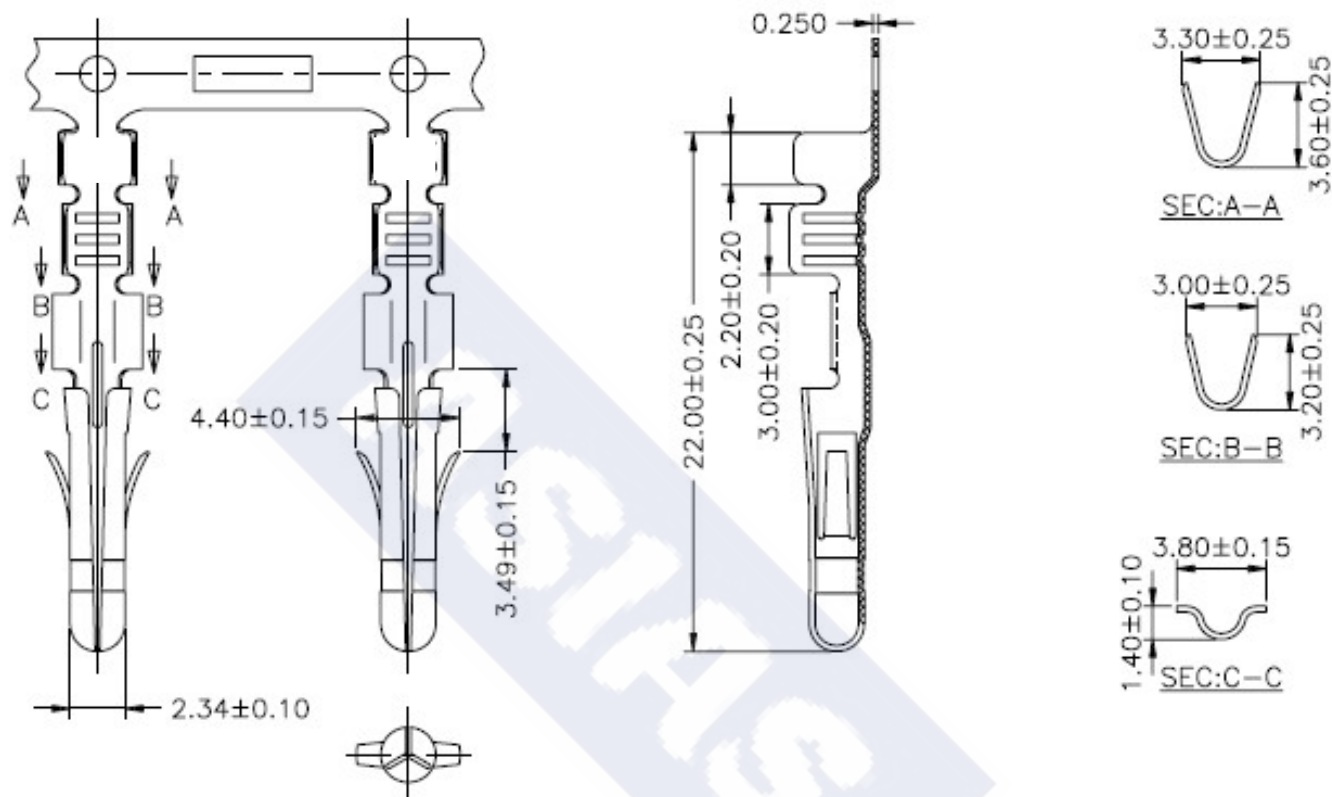

## Ordering Information &amp; Specification

Part NO.	Wire Range	Insulation O.D.	Material	Finish	SPQ
5030JTM-TB	AWG#18~AWG#24	3.10mm(max)	Brass	Tin-plated	5,000 pcs/reel

\*\* Stamping before plating

**ASIAS** ASIAS TECHNOLOGY CO.,LTD.

DESCRIPTION :  
**5.03mm Pitch,  
 Crimp Terminal, Male Type**  
 PART NO. :  
**5030JTM-TB**

## GENERAL TOLERANCE

X.X  $\pm 0.25$   
 X.XX  $\pm 0.15$   
 X.XXX  $\pm 0.05$

SCALE : Free

