

RoHS

Reach

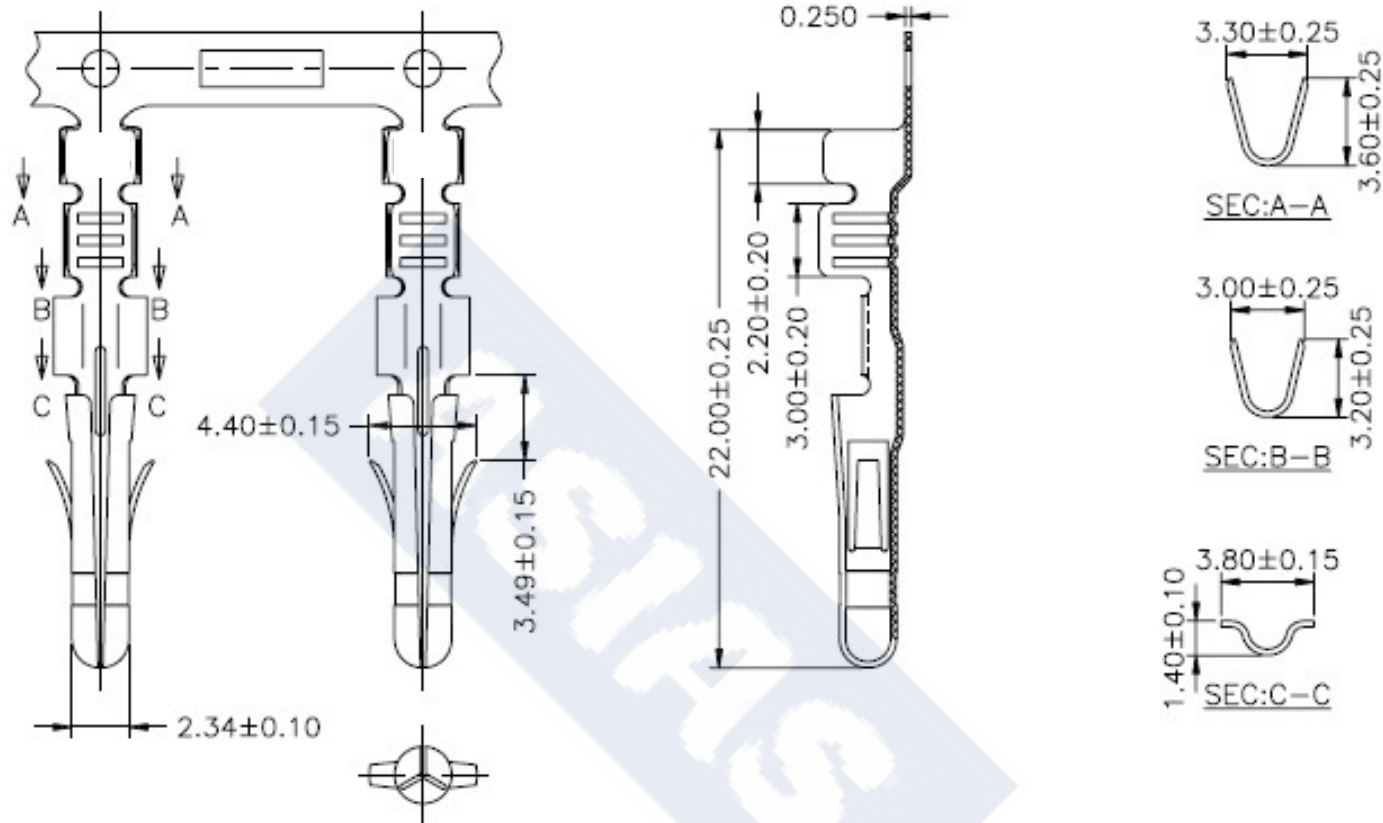

Ordering Information & Specification

Part NO.	Wire Range	Insulation O.D.	Material	Finish	SPQ
5030JTF-TB	AWG#18~AWG#24	3.10mm(max)	Brass	Tin-plated	5,000 pcs/reel

** Stamping before plating

	DESCRIPTION : 5.03mm Pitch, Crimp Terminal, Female Type	GENERAL TOLERANCE	
	PART NO. : 5030JTF-TB	X.X ± 0.25 X.XX ± 0.15 X.XXX ± 0.05	SCALE : Free 