

RoHS

Reach

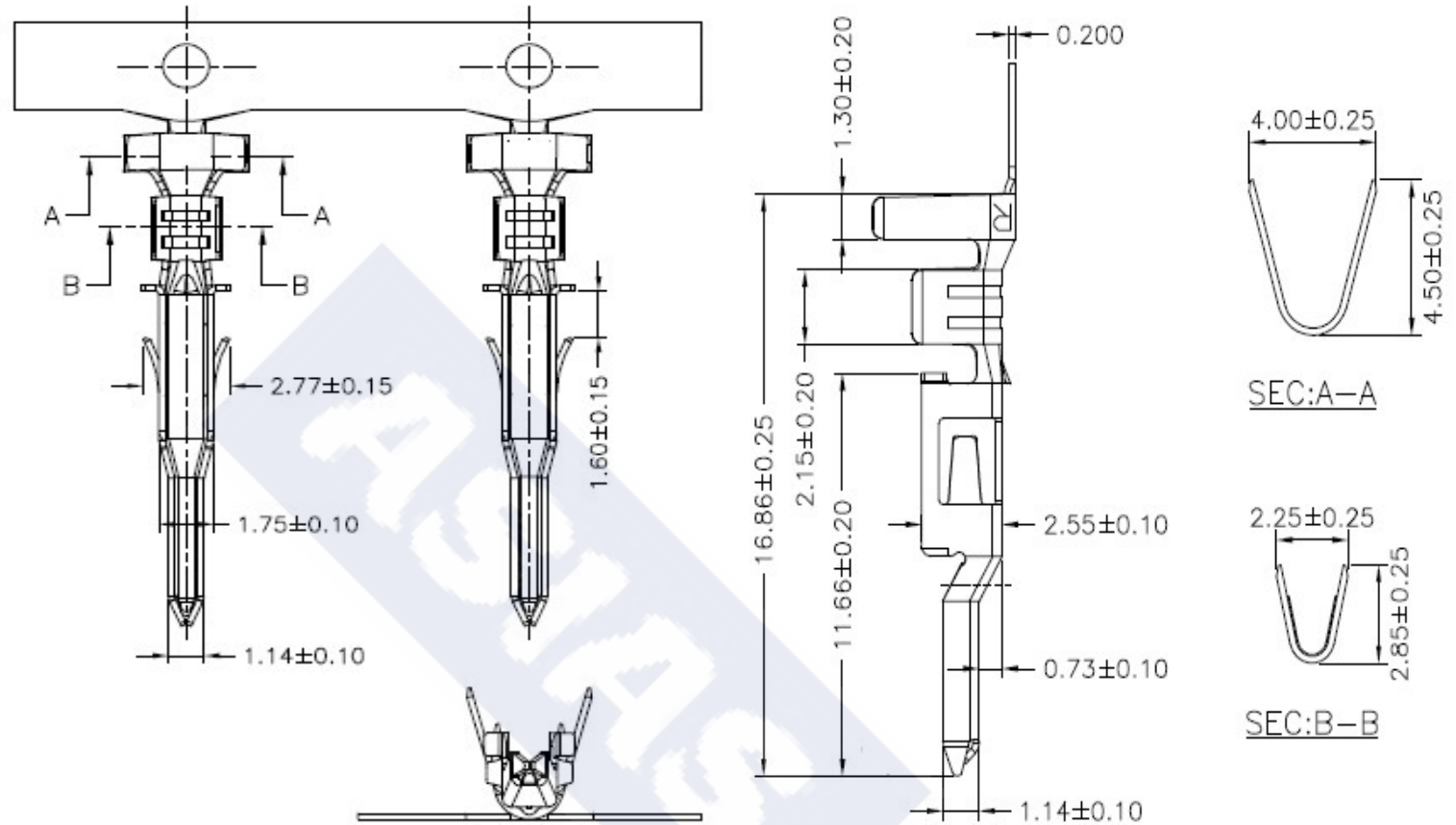

Ordering Information & Specification

Part NO.	Wire Range	Insulation O.D.	Material	Finish	SPQ
4255JTM-TB-H	AWG#16~AWG#24	3.10mm(max)	Brass	Tin-plated	5,000 pcs/reel

** Stamping before plating

ASIAS ASIAS TECHNOLOGY CO.,LTD.

DESCRIPTION :
4.20mm Pitch,
Crimp Terminal, Male Type,
H Type

PART NO. :
4255JTM-XX-H

GENERAL TOLERANCE

X.X ± 0.25
X.XX ± 0.15
X.XXX ± 0.05

SCALE : Free

