

RoHS

Reach

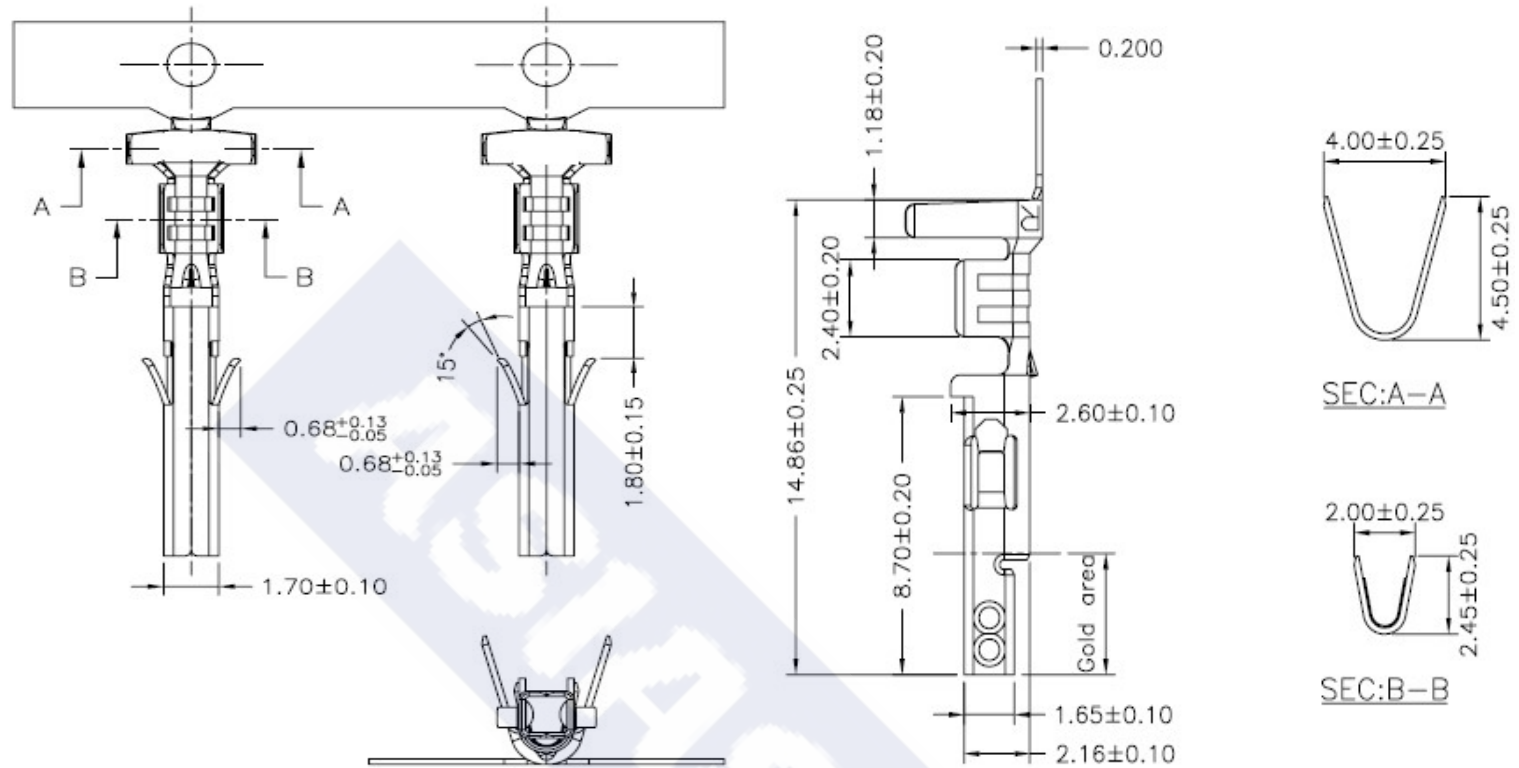

Ordering Information & Specification

Part NO.	Wire Range	Insulation O.D.	Material	Finish	SPQ
4255JTF-TB-A	AWG#18~AWG#24	3.10mm(max)	Brass	Tin-plated	5,000 pcs/reel
4255JTF-TP-A	AWG#18~AWG#24	3.10mm(max)	Phosphor Bronze	Tin-plated	5,000 pcs/reel
4255JTF-HB-A	AWG#18~AWG#24	3.10mm(max)	Brass	Gold-flash	5,000 pcs/reel

** Stamping before plating

ASIAS ASIAS TECHNOLOGY CO.,LTD.

DESCRIPTION :
4.20mm Pitch,
Crimp Terminal, Female Type,
A Type

PART NO. :
4255JTF-XX-A

GENERAL TOLERANCE

X.X ± 0.25
X.XX ± 0.15
X.XXX ± 0.05

SCALE : Free

