

RoHS

Reach

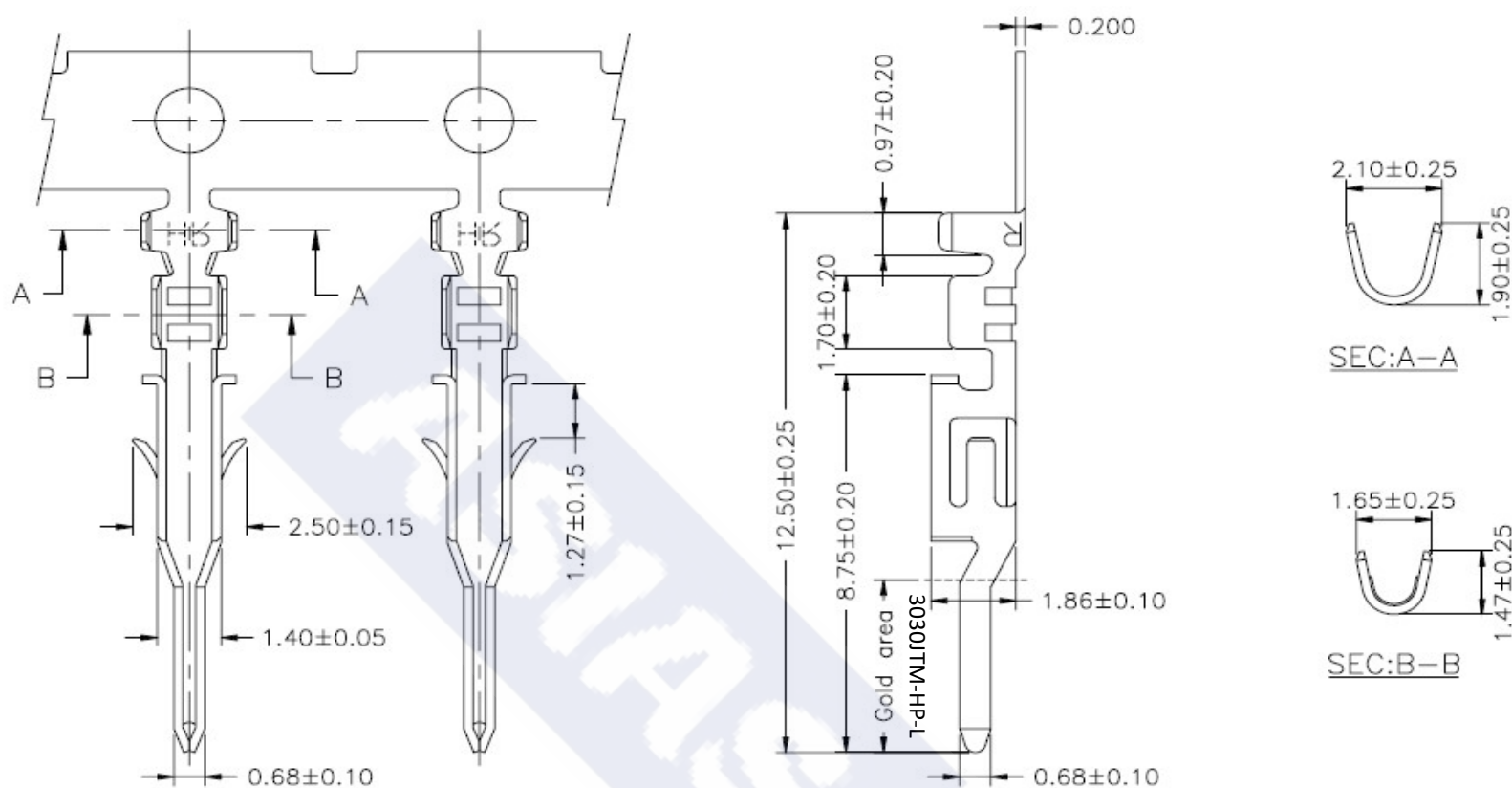

Ordering Information & Specification

Part NO.	Wire Range	Insulation O.D.	Material	Finish	SPQ
3030JTM-TP-L	AWG#26~AWG#30	1.27mm(max)	Phosphor Bronze	Tin-plated	15,000 pcs/reel
3030JTM-HP-L	AWG#26~AWG#30	1.27mm(max)	Phosphor Bronze	Gold-flash	15,000 pcs/reel

** Stamping before plating

DESCRIPTION :
3.00mm Pitch,
Crimp Terminal, Male Type,
L Type

PART NO. :
3030JTM-XX-L

GENERAL TOLERANCE

X.X \pm 0.25
 X.XX \pm 0.15
 X.XXX \pm 0.05

SCALE : Free

