

RoHS

Reach

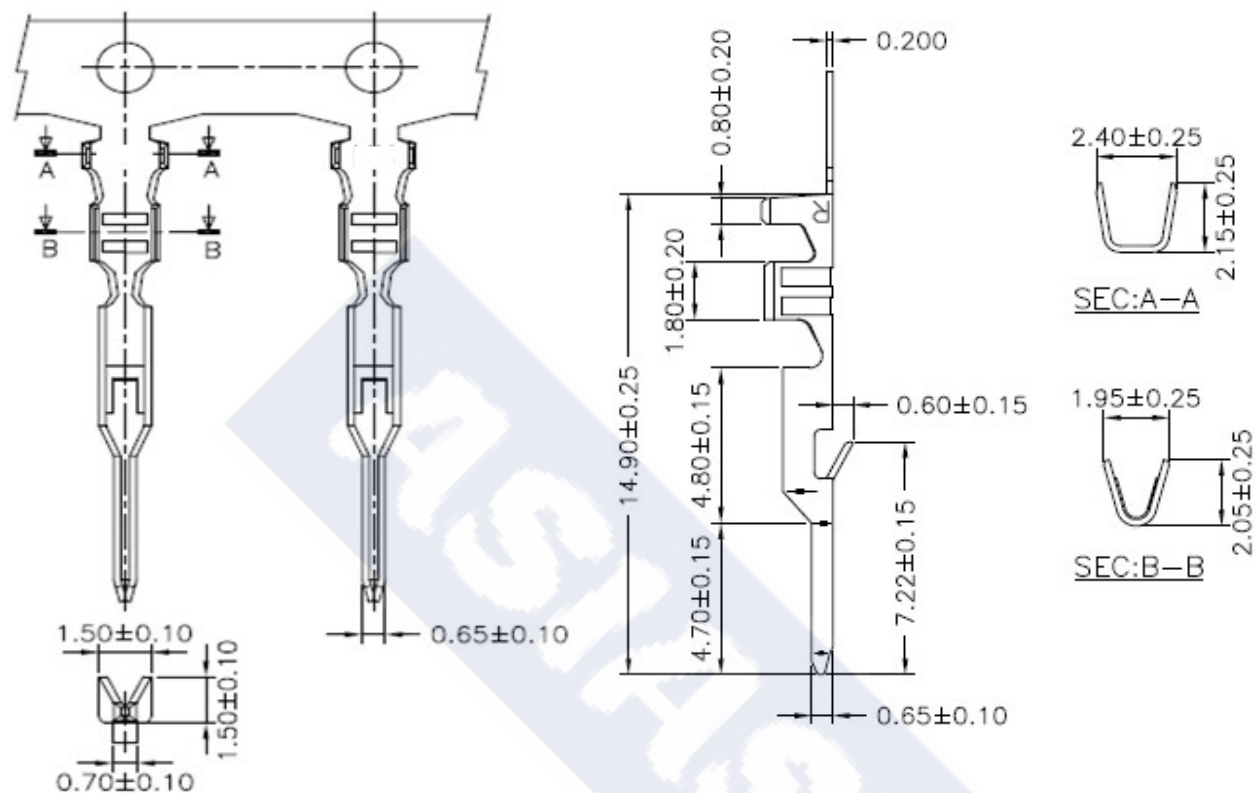

Ordering Information & Specification

Part NO.	Wire Range	Insulation O.D.	Material	Finish	SPQ
2504JTM-TB	AWG#22~AWG#28	1.90mm(max)	Brass	Tin-plated	10,000 pcs/reel
2504JTM-TP	AWG#22~AWG#28	1.90mm(max)	Phosphor Bronze	Tin-plated	10,000 pcs/reel

** Stamping before plating

DESCRIPTION :
**2.50mm Pitch,
 Crimp Terminal, Male Type**

PART NO. :
2504JTM-XX

GENERAL TOLERANCE

X.X ± 0.25
 X.XX ± 0.15
 X.XXX ± 0.05

SCALE : Free

