

RoHS

Reach

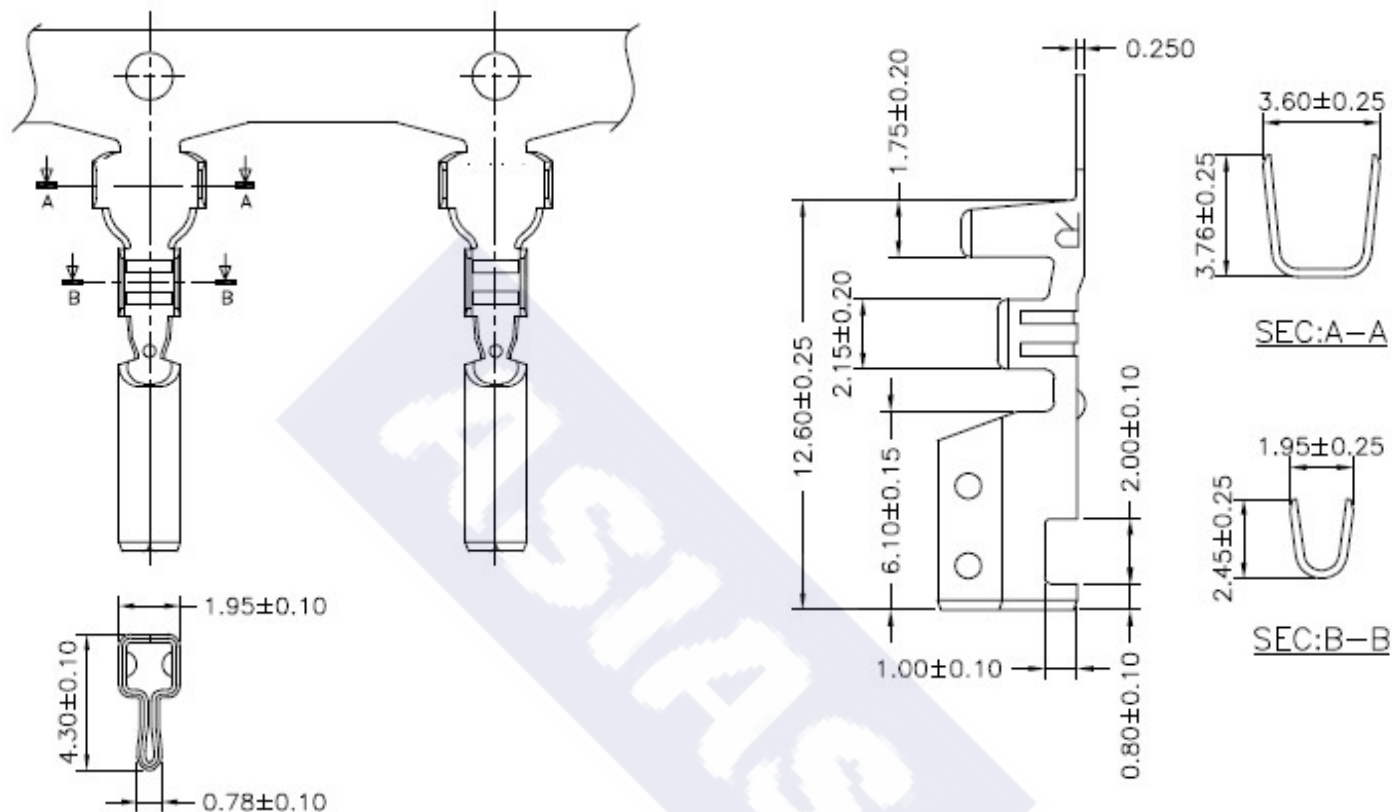

Ordering Information & Specification

Part NO.	Wire Range	Insulation O.D.	Material	Finish	SPQ
3962JT-TB	AWG#18~AWG#22	3.20mm(max)	Brass	Tin-plated	5,000 pcs/reel

** Stamping before plating

DESCRIPTION :
**3.96mm Pitch,
 Crimp Terminal**

PART NO. :
3962JT-TB

GENERAL TOLERANCE

X.X \pm 0.25
 X.XX \pm 0.15
 X.XXX \pm 0.05

SCALE : Free

