

RoHS

Reach

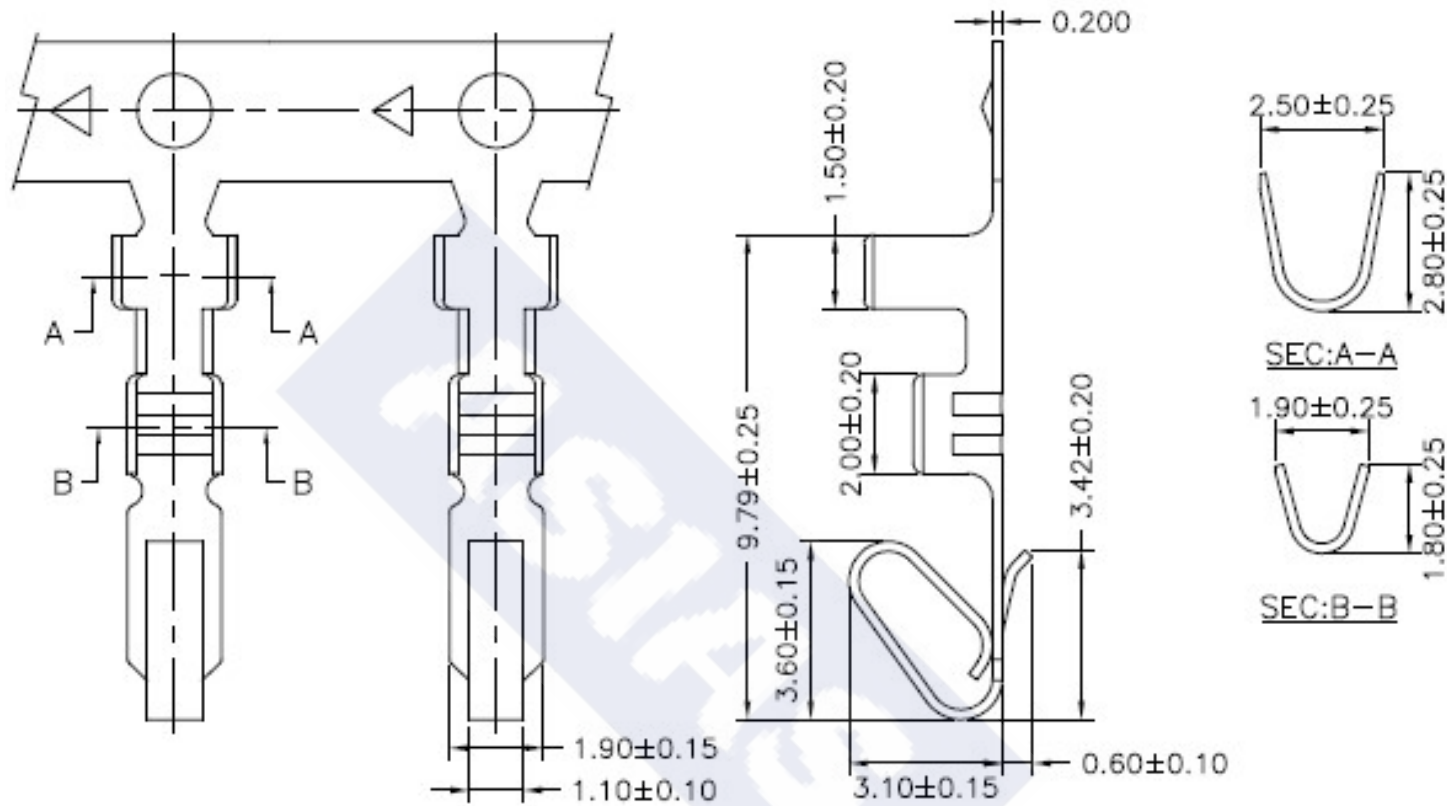

Ordering Information & Specification

Part NO.	Wire Range	Insulation O.D.	Material	Finish	SPQ
2542JT-TP-H	AWG#24~AWG#28	2.00mm(max)	Phosphor Bronze	Tin-plated	8,000 pcs/reel

** Stamping before plating

ASIAS ASIAS TECHNOLOGY CO.,LTD.

DESCRIPTION :
2.54mm Pitch,
Crimp Terminal, H Type

PART NO. :
2542JT-TP-H

GENERAL TOLERANCE

X.X ± 0.25
 X.XX ± 0.15
 X.XXX ± 0.05

SCALE : Free

