

RoHS

Reach

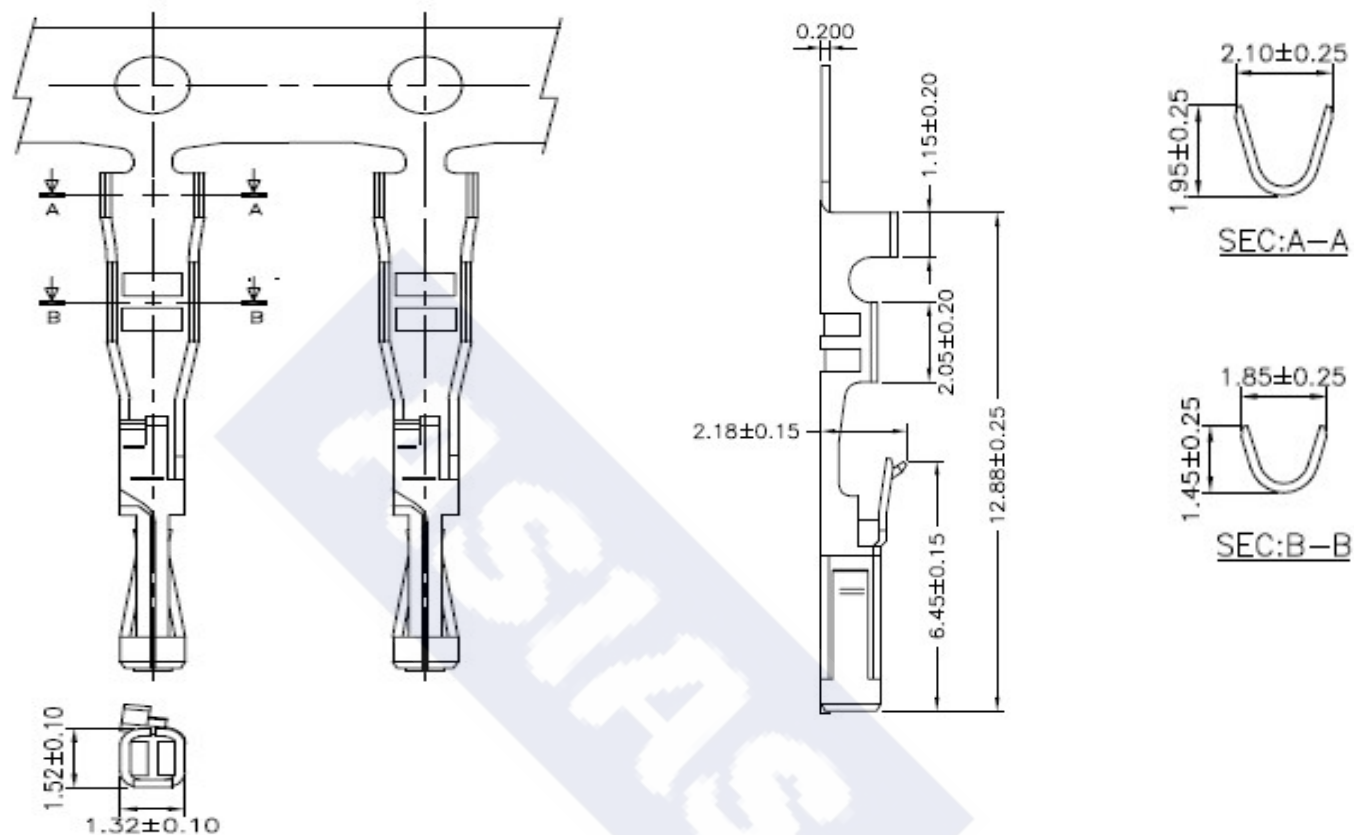

Ordering Information & Specification

Part NO.	Wire Range	Insulation O.D.	Material	Finish	SPQ
2541JT-TP-M	AWG#22~AWG#26	1.63mm(max)	Phosphor Bronze	Tin-plated	10,000 pcs/reel
2541JT-TB-M	AWG#22~AWG#26	1.63mm(max)	Brass	Tin-plated	10,000 pcs/reel

** Stamping before plating

DESCRIPTION :
**2.54mm Pitch,
 Crimp Terminal, M Type**

PART NO. :
2541JT-TX-M

GENERAL TOLERANCE

X.X \pm 0.25
 X.XX \pm 0.15
 X.XXX \pm 0.05

SCALE : Free

