

RoHS

Reach

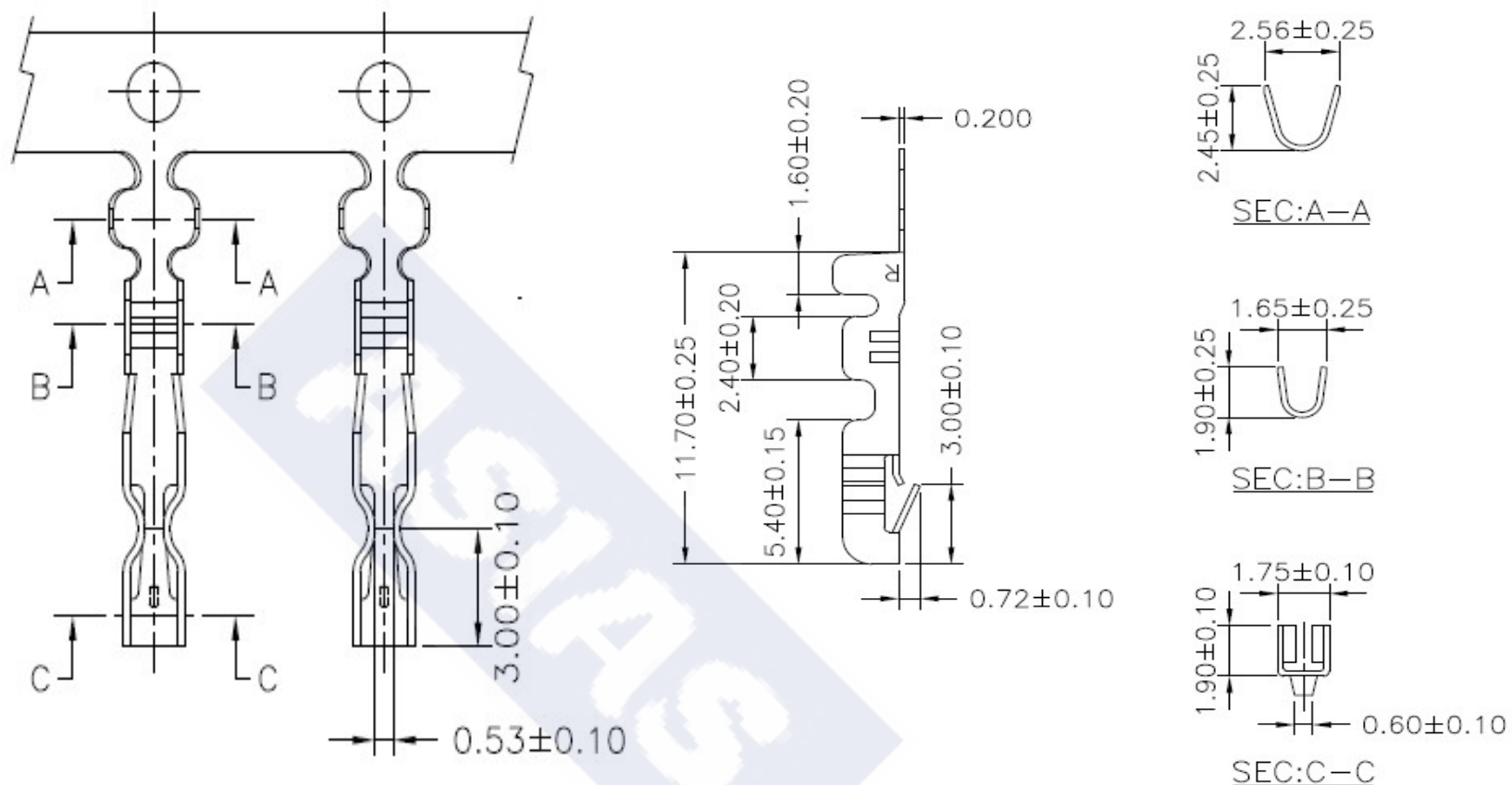

## Ordering Information &amp; Specification

Part NO.	Wire Range	Insulation O.D.	Material	Finish	SPQ
2540JT-TB	AWG#20~AWG#26	1.90mm(max)	Brass	Tin-plated	10,000 pcs/reel

\*\* Stamping before plating

**ASIAS** ASIAS TECHNOLOGY CO.,LTD.

DESCRIPTION :  
**2.50mm Pitch,  
 Crimp Terminal**

PART NO. :  
**2540JT-TB**

## GENERAL TOLERANCE

X.X  $\pm$  0.25  
 X.XX  $\pm$  0.15  
 X.XXX  $\pm$  0.05

SCALE : Free

