

RoHS

Reach

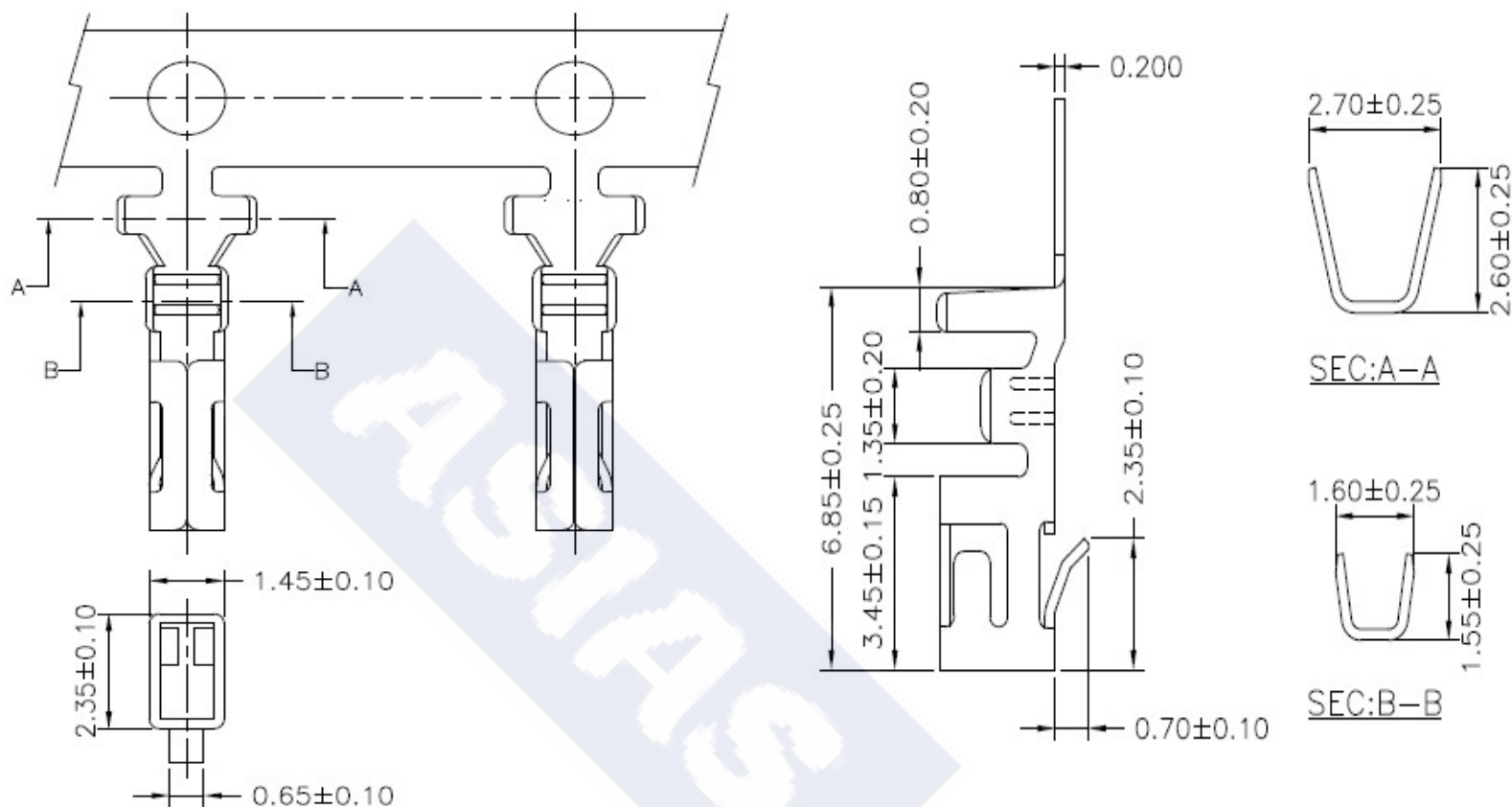

Ordering Information & Specification

Part NO.	Wire Range	Insulation O.D.	Material	Finish	SPQ
2503JT-TB	AWG#22~AWG#28	1.75mm(max)	Brass	Tin-plated	8,000 pcs/reel

** Stamping before plating

DESCRIPTION :
**2.50mm Pitch,
 Crimp Terminal**

PART NO. :
2503JT-TB

GENERAL TOLERANCE

X.X ± 0.25
 X.XX ± 0.15
 X.XXX ± 0.05

SCALE : Free

