

RoHS

Reach

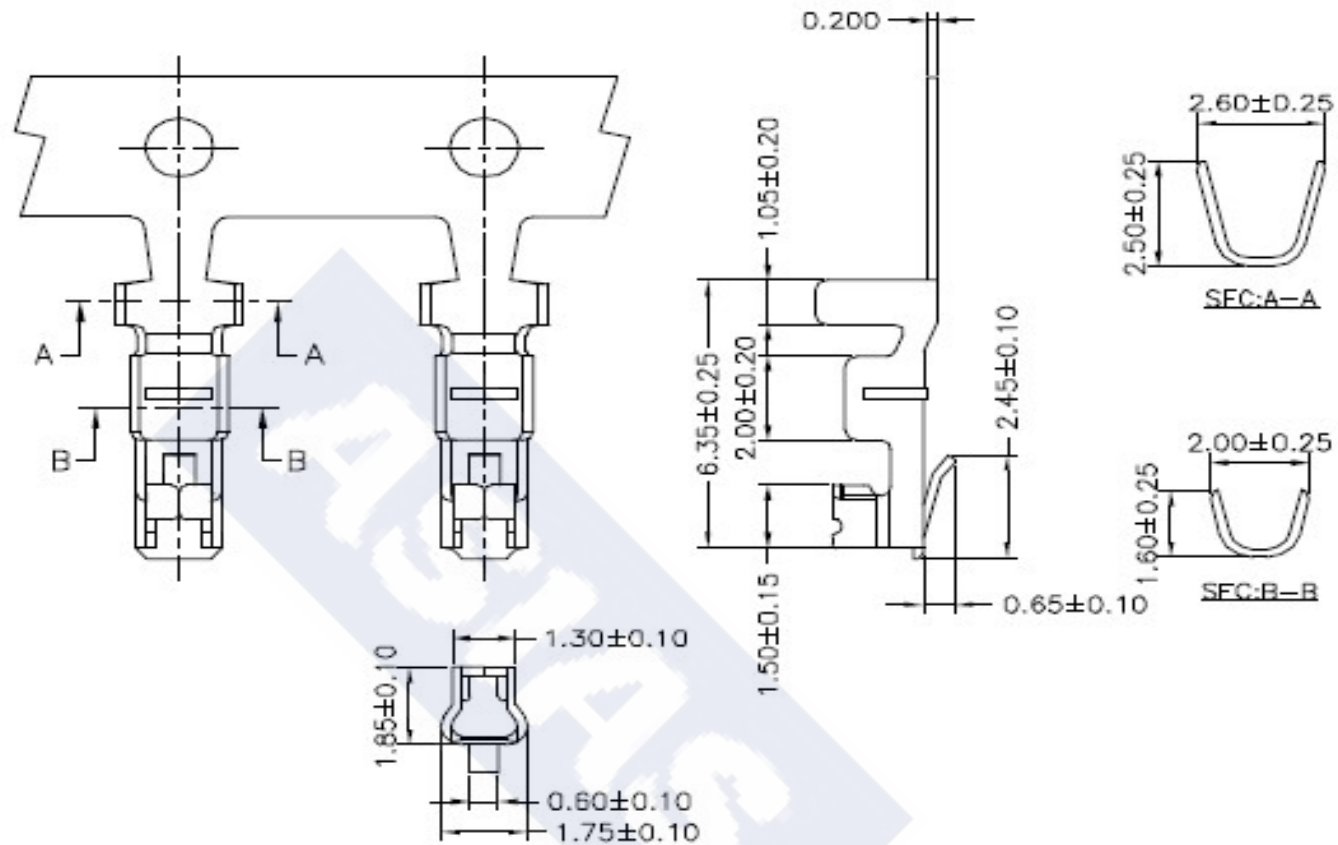

Ordering Information & Specification

Part NO.	Wire Range	Insulation O.D.	Material	Finish	SPQ
2500JT-TP	AWG#22~AWG#28	1.70mm(max)	Phosphor Bronze	Tin-plated	10,000 pcs/reel

** Stamping before plating

ASIAS ASIAS TECHNOLOGY CO.,LTD.

DESCRIPTION :
**2.50mm Pitch,
Crimp Terminal**

PART NO. :
2500JT-TP

GENERAL TOLERANCE

X.X ± 0.25
X.XX ± 0.15
X.XXX ± 0.05

SCALE : Free

