

RoHS

Reach

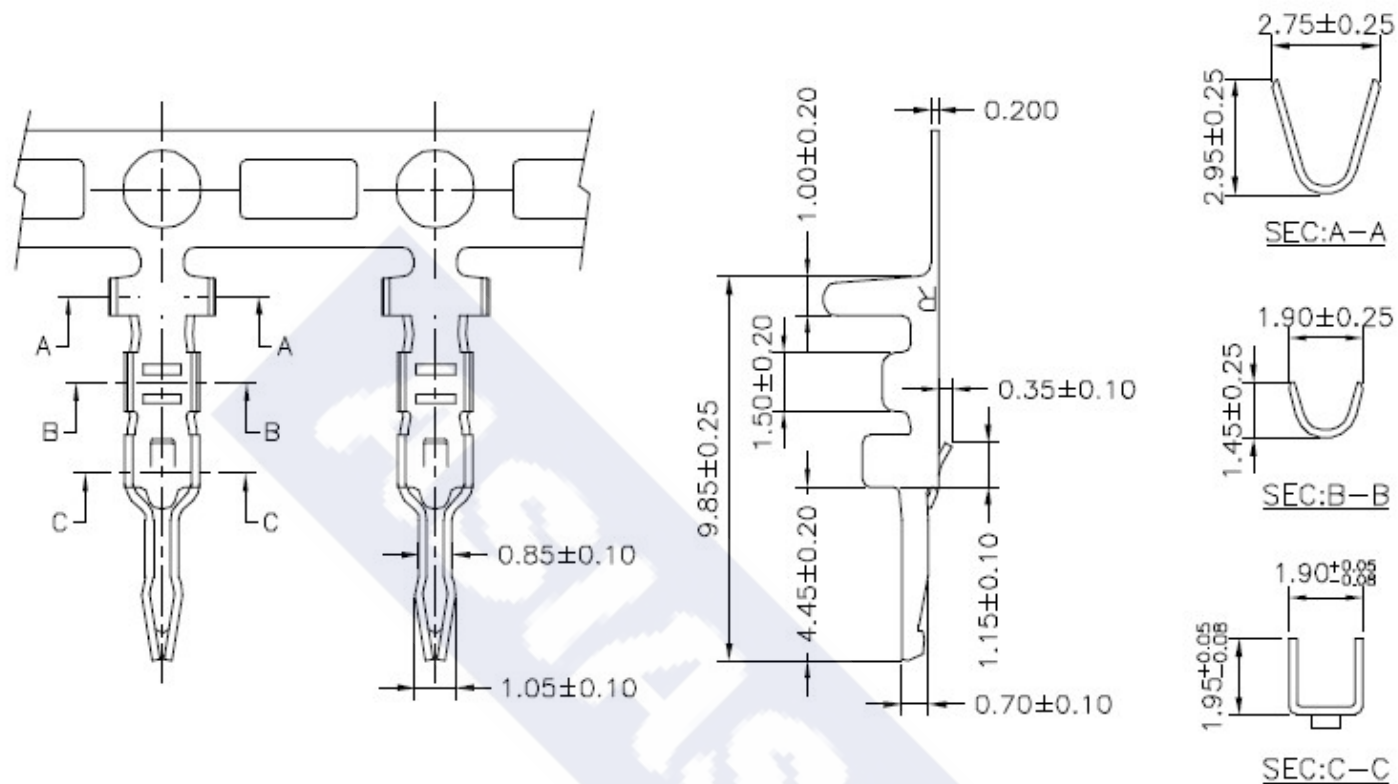

## Ordering Information &amp; Specification

Part NO.	Wire Range	Insulation O.D.	Material	Finish	SPQ
2512JTV-TB	AWG#22~AWG#28	1.70mm(max)	Brass	Tin-plated	10,000 pcs/reel

\*\* Stamping before plating

	<b>DESCRIPTION :</b> <b>2.00mm Pitch,</b> <b>Crimp Terminal, V Type</b>	<b>GENERAL TOLERANCE</b>	
	<b>PART NO. :</b> <b>2512JTV-TB</b>	X.X ± 0.25 X.XX ± 0.15 X.XXX ± 0.05	SCALE : Free 